

SABBATH SCHOOL

Level 5 • Unit 6 • Week 1

SAMUEL AS A CHILD

OBJECTIVE:

To learn that God used Samuel for a special job. God wants us to be like Samuel and not like Eli's sons. The near scale model of the tabernacle will give the children a better understanding and retention of the story about Samuel and many other stories in which the tabernacle is mentioned.

ATTENTION GETTER:

NOTE: This near scale model (1 1/2 inch = 10 feet) of the tabernacle can be used for this lesson and displayed during the next three. This visual prop will help the students relate to the story of Samuel, as a child, growing up right in the middle of the tabernacle activity as a helper to the aging Eli. The tabernacle was built in the first year of the Exodus under the supervision of Moses and was used until the building of the temple by Solomon. This scale model can be helpful in the study of many lessons during this time. It can also be used with the Atonement lesson to show the location of the Holy of Holies that the high priest entered.

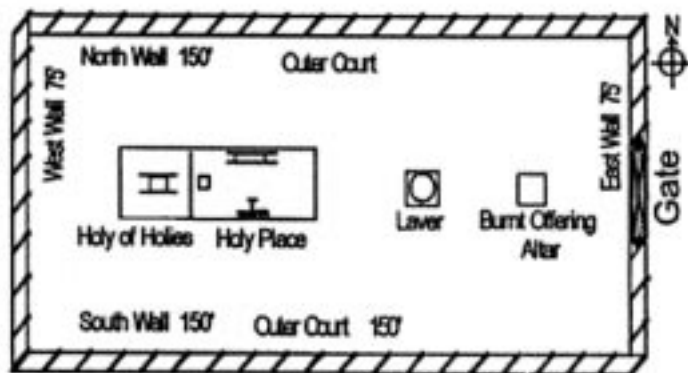

MATERIALS NEEDED TO PREPARE PIECES FOR MODEL:

Two sheets of poster board

Pair of scissors

Ruler or yardstick

Small amounts of gold, silver, bronze, red, blue, purple, white and green poster paints or crayons

64 toothpicks

White, gray, red, and brown fabric, 6 3/4 x 9 inches each

INSTRUCTIONS FOR MAKING THE PIECES FOR THE MODEL:

Prepare the pieces for the tabernacle ahead of time so that the children can assemble it during class. If

need be, ask a skilled model maker(s) to help you cut, color and assemble this model. This person may be a man, woman or accomplished young person.

1. BASE: From the poster board cut a rectangle 28 x 17 inches. Centered on the poster board, draw a rectangle 22 1/2 x 11 1/4 inches. Paint or color the rectangle light brown and around it green.

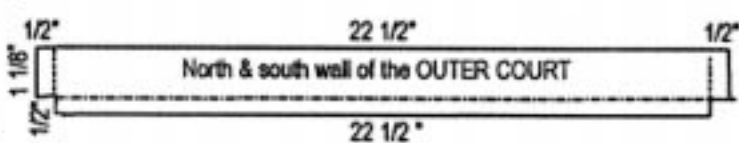

2. WALLS FOR THE OUTER COURT:
 - (a) Cut two pieces of poster board for the north and south sides of the tabernacle measuring 22 1/2 inches plus 1/2 inch on each end (23 1/2 inches total) and 1 1/8 inches high plus 1/2 inch at the bottom (1 5/8 inches total). All walls are white. Start at the top and cut downward 1/2 inch along dotted line, then fold toward the inside along dotted lines—both sides and bottom. To make folding easier, place ruler on the front along dotted line and score lightly with a sharp knife.

- (b) Cut two pieces of poster board for the east and west sides of the tabernacle measuring 11 1/4 inches long plus 1/2 inch on each end (12 1/4 inches total) and 1 1/8 inches high plus 1/2 inch at the bottom (1 5/8 inches total). Start at the bottom and cut upward 1/2 inch along dotted line both sides, then fold toward the inside along dotted lines—both sides and bottom.

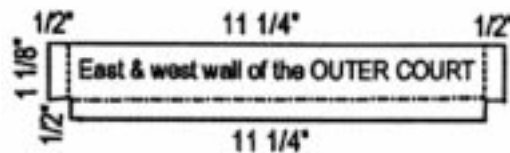

3. CURTAIN FOR THE GATE TO THE OUTER COURT: Draw the curtain (4 1/2 x 1 1/8 inches) for the gate to the outer court on the outside of the east wall of the outer court. Center the curtain on the east (front) wall. Color according to color code. The lines between the colored sections are white. Color code: R = red, W = white, B = dark blue and V = violet.

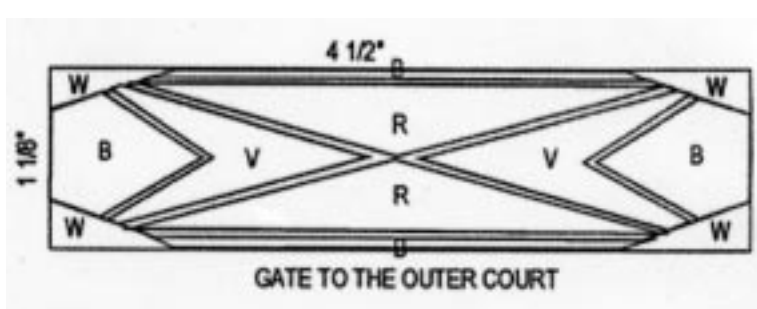

4. POSTS FOR WALLS OF OUTER COURT: Use 56 of the toothpicks for the posts. Cut the widest part to measure 1 1/4 inches long and paint them brown. Paint 3/16 inch at the bottom bronze for the base and 1/8 inch at the top silver for the capitals. North and south walls: Glue a toothpick by the left fold line and one by the right fold line to form the four corner posts. Then space 18 more toothpicks on each wall 1 3/8 inches apart. East and west walls: Starting from the left fold line glue the first toothpick 1 1/4 inch from the fold line. Space seven more on each wall 1 1/4 inches apart. The last toothpick should be 1 1/4 inches from the right fold line. Glue the posts on the east wall in the curtain (gate) area behind the curtain.

5. HOLY PLACE: For the Holy Place (sanctuary) cut one piece of poster board measuring 18 inches long by 2 1/4 inches high plus 1/2 inch on each end. Lightly mark the fold lines according to measurements in the illustration. Fold along horizontal dotted line at the bottom.

On the folded bottom, cut 1/2 inch upward on the vertical fold lines (second, third and fourth dotted lines). On the left side (first dotted line), start at the top and cut 1 1/8 inch downward. On the right side (last dotted line), start at the bottom and cut upward 1 1/8 inch. Fold on all the vertical lines. Color the north, south and west sides gold—inside and outside.

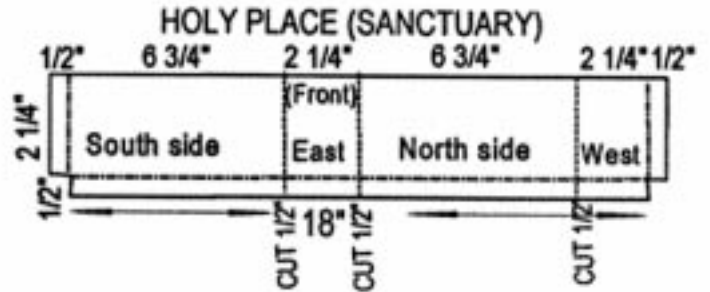

6. CURTAIN FOR THE HOLY PLACE ENTRANCE: Copy the design on the right on the east (front) wall to represent the curtain that hung across the entrance to the Holy Place.

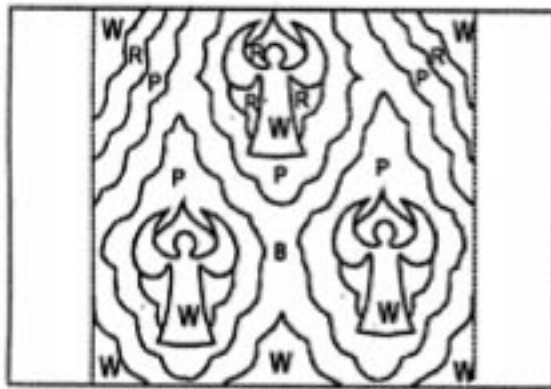

VEIL



CURTAIN FOR THE HOLY PLACE

7. VEIL: Draw the veil for the Holy of Holies on a piece of poster board 2 1/4 inches wide plus 1/2 inch on each end by 2 1/4 inches high (total: 3 1/4 x 2 1/4 inches). Color according to color code. Fold on dotted lines towards the back.

8. GRATING FOR ALTAR: Cut poster board 1 5/8 inch square. Paint bronze. Cut to corner 1/4 inch along dotted lines on left and right sides. Then fold along all four dotted lines.

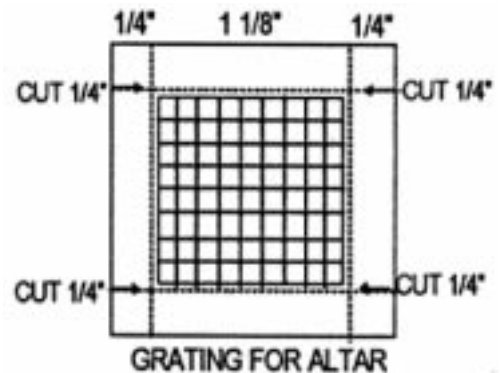

BURNT OFFERING ALTAR: Cut as shown below. Paint bronze. Cut left tab 1/4 inch upward and right tab 1/4 inch downward. Make "horns" 1/4 inch high. Fold backward on dotted lines. Paint two toothpicks bronze. (To be glued on each side when assembling.)

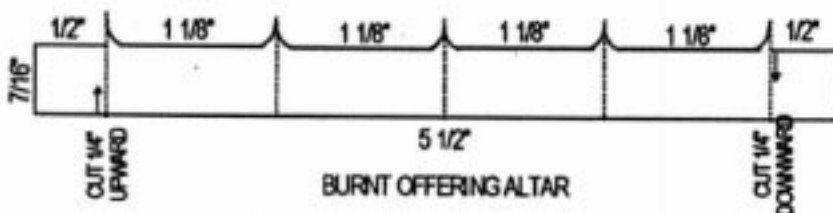

9. LAYER: Paint bronze. Paint circle blue. Cut $\frac{7}{16}$ inch along dotted lines on left and right sides. Then fold along all four dotted lines.

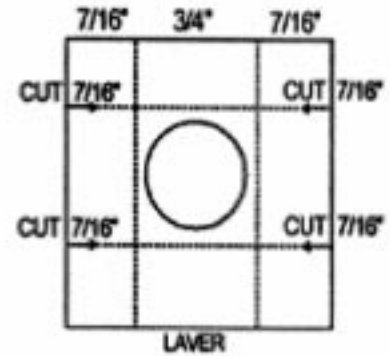

10. SHOWBREAD TABLE: (Larger than scale.) Cut according to pattern shown. Paint gold. Fold vertical lines toward the back. Fold the horizontal lines toward the front. The tabletop is recessed $\frac{1}{8}$ inch. Paint two toothpicks gold for later use.

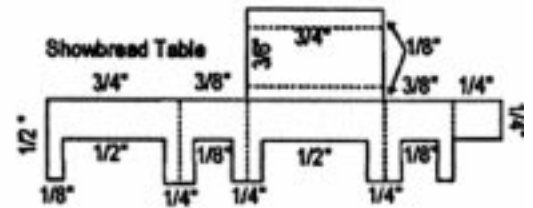

11. LAMPSTAND: (Larger than scale.) Using the pattern shown, draw a candlestick $\frac{3}{4}$ inch high and $\frac{3}{4}$ inch wide. Paint gold. Draw tabs $\frac{1}{2}$ inch on each side of the bottom. At the top of the left tab cut downward halfway. At the bottom of the right tab cut upward halfway.



12. GOLDEN INCENSE ALTAR: (Larger than scale.) Cut a rectangle $1 \frac{3}{4}$ inches wide x $\frac{3}{4}$ inch high with $\frac{1}{4}$ inch "horns." Lightly mark the rectangle according to the illustration. Fold the vertical lines toward the back. Paint gold.

TOP: Make a $\frac{3}{8}$ inch square with $\frac{1}{8}$ inch tabs all around. These are folded upward so as to make a recessed top. Paint gold.

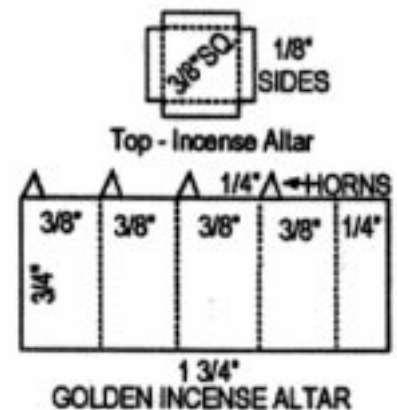

13. ARK OF THE COVENANT: (Larger than scale.) Copy the rectangle on the right according to the measurements given with its bottom piece attached. Fold along dotted lines towards the back. Paint both sides gold.

LID FOR THE ARK: Draw a rectangle $1 \frac{1}{4}$ x 1 inch. Fold on dotted lines toward the back. Cut $\frac{1}{4}$ inch on the straight line on the corners of the rectangle. Paint both sides gold.

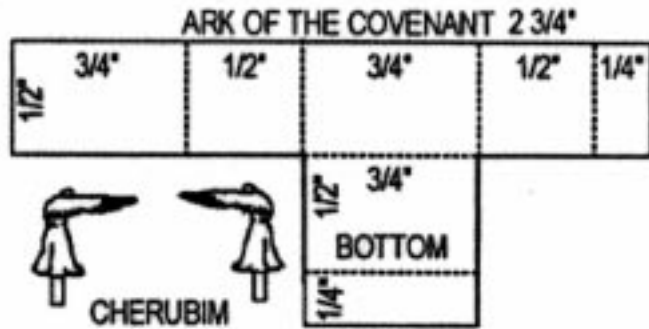
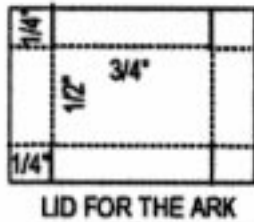

CHERUBIM: Draw two cherubim facing left and two facing right, measuring $\frac{3}{8}$ inch from head to toe and $\frac{3}{8}$ inch from back to wingtip. Glue the two left cherubim to the backs of the two right cherubim. Do not glue the tabs at the bottom together—fold them outward. Paint both sides gold.

14. THE TEN COMMANDMENTS: Draw two stone tablets— $\frac{1}{2}$ x $\frac{1}{4}$ inch each—to represent the Ten Commandments. Paint them gray.



15. Make a label for each of the items. Example:

HOLY PLACE

16. Take four pieces of cloth (white, gray, red and brown), each measuring $6 \frac{3}{4}$ x 9 inches. On the white piece of cloth, draw cherubim like the design that is on the veil. Place this on the Holy Place (sanctuary) first. It forms the ceiling. For the second covering, on the gray cloth print "WOVEN GOATS' HAIR." For the third covering, on the red cloth print "RAMS' SKIN DYED RED." For the fourth covering, on the brown cloth print "BADGERS' SKIN."

MATERIALS NEEDED FOR ASSEMBLY IN CLASS: Glue

DIRECTIONS FOR ASSEMBLY IN CLASS:

1. WALLS FOR OUTER COURT: Slip the cut ends of the east and west walls down on the north and south walls to form a rectangle. Glue corners to the inside walls. Turn the bottom tabs inward, then center and glue the walls to the poster board base.

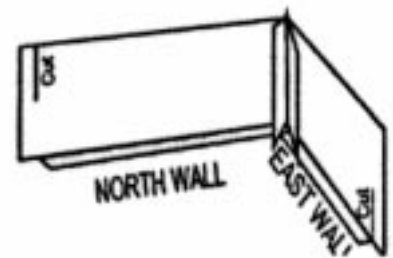

2. HOLY OF HOLIES: Slip the cut ends of the Holy of Holies (sanctuary) into each other with the tabs on the inside. Glue tabs to inside walls. Turning the bottom tabs inward place west wall (back) of the Holy of Holies $3 \frac{3}{4}$ inches from the west wall of the outer court, centering it between the north and south walls. Glue the bottom tabs to the poster board base.

3. VEIL: Glue the tabs (turned toward the back) of the veil $2 \frac{1}{4}$ inches from the west (back) wall of the Holy of Holies. This will make a square room and take up one third of the Holy Place (sanctuary).

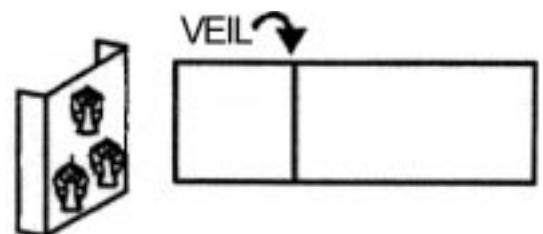

4. GRATING FOR ALTAR: Fold along dotted lines toward the back. Glue the corners to the inside of the smaller pieces.

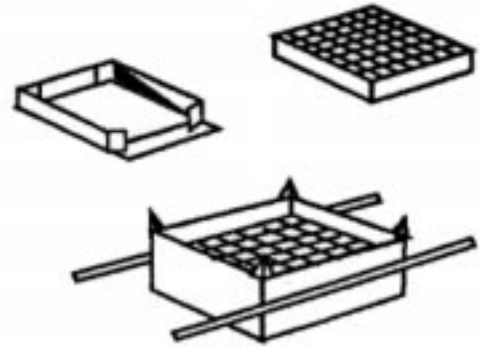

BURNT OFFERING ALTAR: Slip the left tab down on the right tab. Glue ends to inside. Center and glue two bronze painted toothpicks—one on each side. Position the grate on the inside of the burnt offering altar halfway down.

5. LAVER: Assemble just like the grating for the altar.

6. SHOWBREAD TABLE: Fold vertical lines toward the back. Glue the 1/4 inch tab to the inside. Fold horizontal lines toward the front. Glue the fold on top to the other side of the table. Glue gold toothpicks to sides.



7. LAMPSTAND: Slip the right tab over the left tab so that the candlestick will stand up.

8. GOLDEN INCENSE ALTAR: Fold the vertical dotted lines toward the back. Glue the 1/4 inch tab toward the inside of the altar.

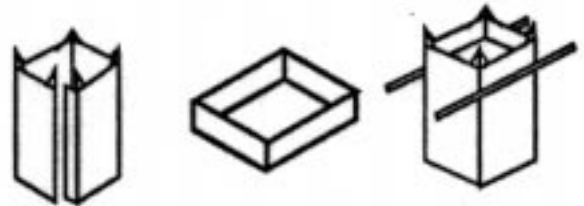

TOP: Fold the sides to the front and glue to inside of incense altar. The top is recessed.

9. ARK OF THE COVENANT: Fold the vertical dotted lines toward the back and glue the 1/4 inch tab inside the Ark. Fold the bottom piece toward the back and glue the 1/4 inch tab inside the Ark. Glue two gold-painted toothpicks on the longer sides of the Ark.



LID FOR THE ARK: Follow directions in step 4 for grating.

CHERUBIM: Spread the tabs on the bottom of the cherubim outward and glue to the top of the lid. This is the Mercy Seat.

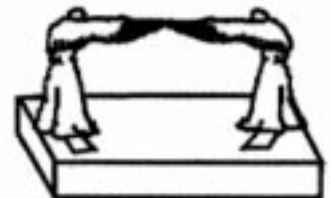

10. THE TEN COMMANDMENTS: Put the Ten Commandments in the Ark of the Covenant and place the lid on top.

11. Using the diagram at the beginning of the lesson put each of the items in its proper place and then glue the correct label by each item.

12. When everything is in its proper place, cover the Holy Place with the four coverings. First covering—cherubim design; second covering—woven goats' hair; third covering—rams' skin dyed red and fourth covering—badgers' skin.

BIBLE LESSON:

NOTE: Make a copy of the Bible lesson, "Samuel as a Child," for each student. Let the children take turns reading. Ask the class the question in the section below that corresponds with the number at the end of a paragraph. Point out that God has not left us without instructions on the right way to live. Down through the ages, He inspired chosen men to record the stories of people in a book—the Bible—as object lessons for us to learn from and apply in our own lives.

1 Corinthians 10:11 "All these things happened to them as examples—as object lessons to us—to warn us against doing the same things; they were written down so that we could read about them and learn from them in these last days as the world nears its end" (The Living Bible).

Ask:

- Q. 1. What lesson can we learn from the story about the tabernacle?
A. God provides for our physical as well as our spiritual needs. Using the back wages the Egyptians owed the Israelites, God provided them with so much wealth (physical) that Moses had to tell the people to stop giving offerings because he had more than enough to build the Tabernacle (spiritual). The tabernacle was the spiritual center of Israelite life.
- Q. 2. What lesson can we learn from this paragraph?
A. When people get lax and stop studying and learning about God, they lose His precious knowledge. They begin leaning on their own understanding, which is always faulty, and end up with customs contrary to God's laws. This eventually brings great unhappiness.
- Q. 3. What lesson can we learn from this part of the story?
A. When we have a problem, we should take it to God and He will help.
- Q. 4. What lesson can we glean from this part of the story?
A. God watches over His ministry very closely and will remove those who defile it.
- Q. 5. What can we learn from this one sentence?
A. God will always provide faithful prophets (ministers) who will teach and do according to what is in God's heart and mind.
- Q. 6. What is the overall lesson to be learned from the early years of Samuel?
A. God is mindful of children as well as adults. He can use an obedient child as well as an adult in His plan for the salvation of mankind. He listens to and answers their prayers also. Ask the children if they found any other lessons that were not mentioned.

SAMUEL AS A CHILD

The children of Elkanah the Levite and Peninnah, his wife, frolicked behind the slow moving wagon as they made their way to Shiloh. From time to time, Elkanah would stop the oxen and they would happily climb into the wagon and gather around Peninnah while she told them stories about the tabernacle in the wilderness. As Peninnah painted pictures in her children's minds of the tabernacle, Elkanah would slip in a detail or two every so often. "Almost 400 years have passed, since the Israelites built the tabernacle in the wilderness. Under the guidance of Moses, they carefully followed the plans God gave him." Peninnah continued, "This beautiful gleaming tabernacle, where we go to worship God on the Holy Days, was built by our forefathers. They used the gold, silver and other treasures they had received from the Egyptians for their years of slavery to build the tabernacle." Finishing the story Elkanah said, "It is God's temporary dwelling place." By this time, everyone was caught up in the happy festive mood—everyone except Hannah. Hannah, the other wife of Elkanah, longed to have children of her own. (1)

The people, having fallen away from God, lost much of the knowledge of His laws. Because of this, customs contrary to God's intent, such as having more than one wife, became acceptable. Elkanah always observed God's Holy Days and obeyed God's ways to the best of his understanding. Those Israelites who desired to observe the annual Sabbaths came from far and near to Shiloh where the tabernacle and the Ark of the Covenant were located. They came to worship God and brought unblemished animals to be sacrificed. Elkanah brought an unblemished animal to be offered as a peace offering in the tabernacle. According to the law of the offerings, most of the meat offered was returned to the one who brought it. It was then eaten at the family meals during the feast days. (2)

One day, when they had sat down to dinner, Elkanah showed more love and attention to Hannah and gave her a double portion of meat. Jealous of Hannah, Peninnah taunted her about not having any children of her own. This caused Hannah much sorrow. Peninnah began to whisper mean and hurtful remarks to Hannah about being childless. Holding back tears, Hannah left the dinner table so that she could be alone. After a while, she went over to the tabernacle.

While sitting at the entrance of the tabernacle, Eli, the high priest, noticed Hannah crying bitterly and in deep anguish as she prayed to God. In her prayer she vowed: "O God of heaven, if You will look down upon my sorrow and answer my prayer and give me a son, I will give him back to You, and he'll be Yours for his entire lifetime. His hair shall never be cut."

Eli, the high priest, thought she had been drinking because her lips were moving yet she was not making a sound. "Why do you come here in such a drunken state?" asked Eli. "Get rid of your wine."

"Oh, no my Lord!" Hannah replied. "Please don't think I am drunk. I am very sad and was pouring my heart out to God. I am childless and was bringing my problem to God," she explained to Eli. "I told God that if He blessed me with a baby boy, I would give up the baby so that he could become God's servant for the rest of his life."

Believing her, Eli said, "Go in peace, and may God grant you what you have asked of Him."

In the course of time, God blessed Hannah with a baby boy and she named him, Samuel. When he was about three years old, Hannah took him to Shiloh and presented him to Eli, the high priest. It took great courage to give up her only child. He was to be reared and instructed in the simple duties he would at first be required to perform at the tabernacle. Samuel was dressed in a linen ephod and each year his mother, Hannah, would make a coat for him and bring it when she went to the tabernacle for the holy days. (3)

Eli's sons, Hophni and Phinehas, were wicked men and, having no regard for God, defiled the priesthood. People began staying away from the tabernacle and within a short time they turned to idolatry. Eli knew of their sins against God and their mistreatment of the people, but he did nothing to stop them. It was at this time that a man of God came to Eli and said, "God has sent me to tell you that He is well aware that you and your sons have sinned against Him. By allowing them to steal from those who have brought offerings, you honor your sons above God. This is idolatry!"

Eli began to feel very uneasy. He should have felt sorrow, corrected his sons and asked God for forgiveness.

The man of God continued, "While still in Egypt, God chose the family of Aaron for the priesthood and gave explicit instructions to follow. You and your sons have failed miserably in carrying out the duties of the priesthood. God cannot continue to use men like you and your sons. As a sign to you, both Hophni and Phinehas will die on the same day. Think about how you have brought this on yourselves."

By now, Eli was both speechless and noticeably ill. (4)

Finishing his message, the man of God said, "God will raise up a faithful priest, who will do according to what is in God's heart and mind." (5)

Samuel eagerly learned the duties of the tabernacle and ministered before the Eternal God under Eli, the high priest. One night, when Samuel was about 12, he was awakened by a voice speaking his name. Thinking Eli had called, Samuel hurried to his bedroom. "Here I am, sir," said Samuel.

"I did not call you, Samuel. Go back to sleep," answered Eli.

Twice more this happened before Eli realized that God was calling Samuel. "Go back to bed and if God calls again, say, 'Speak, for your servant is listening,'" said Eli.

Samuel returned to his bed. When he heard God call his name, he answered, "Speak, for your servant is listening."

Then God spoke to Samuel telling him those very same things that the man of God told Eli. God was now speaking to Samuel and bypassing Eli. The next morning Eli insisted that Samuel tell him all that God had said. This he reluctantly did. Several years went by before the judgment against Eli and his sons came to pass. During this time, Samuel grew up to become a well-known young man of great wisdom and intelligence. Samuel prophesied with great accuracy and all Israel came to know him as God's chosen prophet. (6)

LESSON APPLICATION:

Using the scale model of the tabernacle, ask:

- Q. 1. Can anyone tell me what this is a scale model of?
A. It is a scale model of the tabernacle in the wilderness.
- Q. 2. Can anyone show where Eli, the high priest, was sitting when he saw Hannah?
A. Eli was sitting by the entrance to the tabernacle.
- Q. 3. Where was Hannah when Eli saw her praying to God?
A. In front of the tabernacle because Eli was able to see her from where he sat.
- Q. 4. The Israelites brought unblemished animals to the tabernacle to be sacrificed on the burnt offering altar. Where is the altar located?
A. It is in the outer court and the first thing to be seen when entering the tabernacle.
- Q. 5. Where is the Holy of Holies located?
A. In a room which made up the latter third of the Holy Place.
- Q. 6. What is in the Holy of Holies?
A. The Ark of the Covenant, an omer of manna and Aaron's rod that budded (Hebrews 9:4; Exodus 16:33)..
- Q. 7. What is inside the Ark of the Covenant?
A. The stone tablets upon which the Ten Commandments are written.

MUSIC:

Teacher's choice from the United Church of God hymnal.

MEMORY VERSE:

1 Corinthians 10:11 "Now all these things happened to them as examples, and they were written for our admonition, upon whom the ends of the ages have come."

family activity

THE POINT:

To learn that God used Samuel for a special job. God wants us to be like Samuel and not like Eli's sons. We constructed a near scale model of the tabernacle to give a better understanding of the story of Samuel and many other stories in which the tabernacle is mentioned.

FAMILY TOGETHER TIME:

The lesson for this week was about Samuel who began serving God when he was about three years old. Because Hophni and Phinehas, Eli's two sons, defiled the priesthood and Eli did nothing about it God sent one of His servants to prophesy what would happen to his two sons. God's servant also told Eli that God would choose from Aaron's other descendants a faithful high priest. The lesson ended with Samuel repeating to Eli what God said would happen to Hophni and Phinehas.

Take turns with your child reading "the rest of the story." Read 1 Samuel 4:1-18 to find out the details of how it came about that Hophni and Phinehas lost their lives and what happened to Eli and the Ark of the Covenant.

As you read, discuss the lessons that can be learned from the "the rest of the story."

MEMORY VERSE:

1 Corinthians 10:11 "Now all these things happened to them as examples, and they were written for our admonition, upon whom the ends of the ages have come."